

LIGHT FIXTURE SHALL BE MANUFACTURED BY THE PENNSYLVANIA GLOBE LIGHT COMPANY, 322 SHAW ROAD, NORTH BRANFORD, CT 06474. (203)44-7149. MODEL "BALLEAST" OR APPROVED EQUIV. ALL OTHER INSTALLATION REQUIREMENTS SHALL CONFORM WITH THE NORTHAMPTON TOWNSHIP ORDINANCES.

**LIGHT FIXTURE DETAIL**

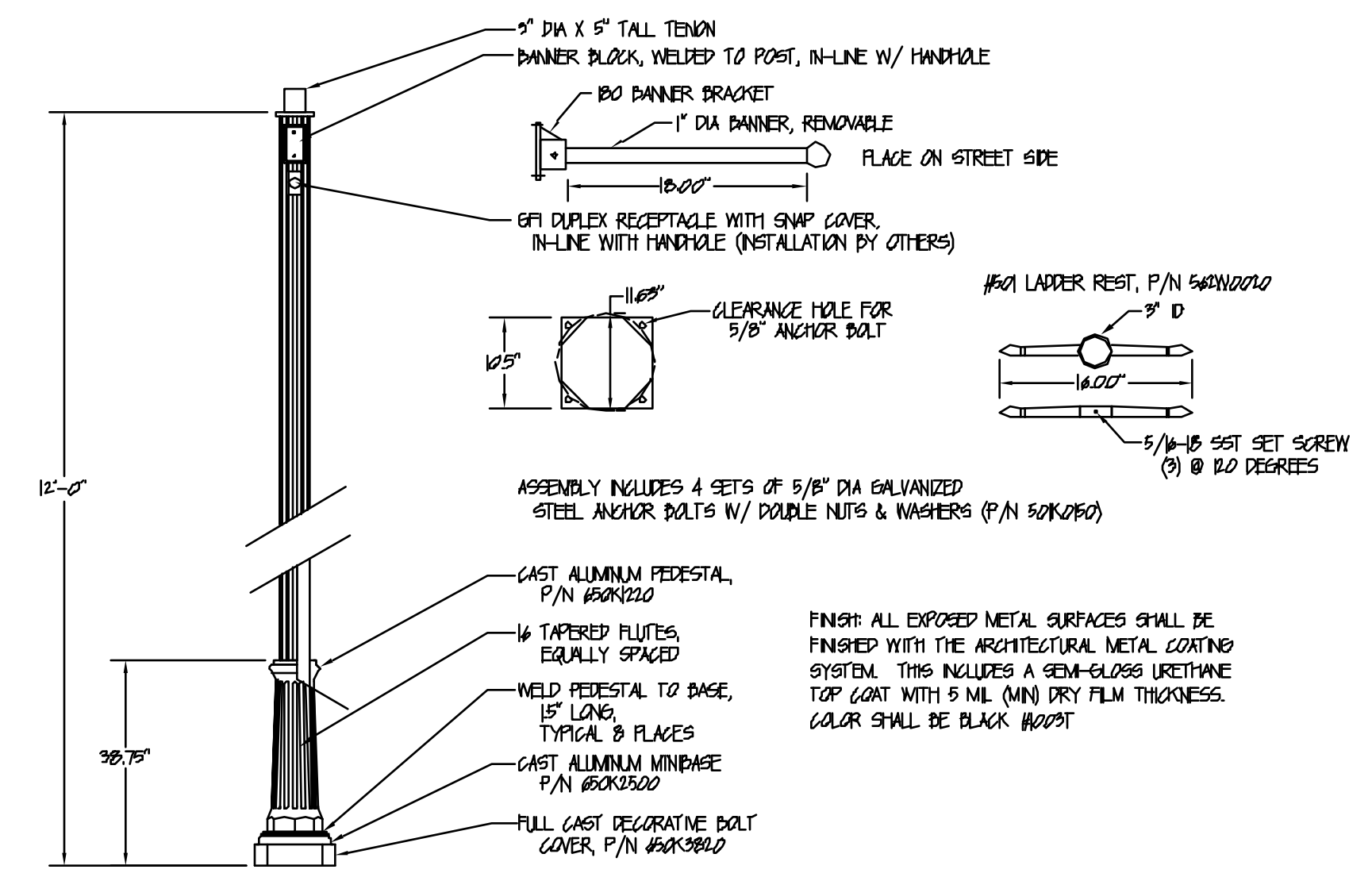

LIGHT POST SHALL BE MANUFACTURED BY THE PENNSYLVANIA GLOBE LIGHT COMPANY, TRADITIONAL FLUTED POST (P/N 500010) OR AFFRATED EQUAL. LIGHT FIXTURE SHALL BE MOUNTED AT A HEIGHT OF TWELVE (12) FEET. ALL OTHER INSTALLATION REQUIREMENTS SHALL CONFORM WITH THE NORTHAMPTON TOWNSHIP ORDINANCES.

**LIGHT POST DETAIL**

NOTE: WHERE PROPOSED LIGHTING CAN NOT BE PLACED AS SHOWN ON THIS PLAN DUE TO EXISTING PHYSICAL INFRASTRUCTURE (DRIVEWAYS, UTILITIES, SIGNAGE, ETC.) THE LIGHTING SHALL BE INSTALLED AS CLOSE TO THE LOCATION SHOWN AS POSSIBLE. TO ENSURE UNIFORM LIGHTING DISTRIBUTION THE SPECIFIED LIGHTING SHALL NOT BE SPACED AT INTERVALS GREATER THAN 175 FEET APART, AND NOT LESS THAN 105 FEET. WHERE EXISTING LIGHTING FIXTURES EXIST, THEY SHALL BE REPLACED WITH THE SPECIFIED LIGHTING FIXTURE EXCEPT WHEN THE LIGHTING FIXTURE IN QUESTION IS INSTALLED AS A MEANS OF SECURITY LIGHTING.

\* LOT LINE LOCATIONS ARE APPROXIMATE, BASED ON AVAILABLE TAX PARCEL INFORMATION

**LEGEND**

- PROPOSED NORTHAMPTON TOWNSHIP LAMP POST

PENNSYLVANIA ONE CALL SYSTEM, INC.

325 14th Run Road  
West Mills, Pennsylvania  
15122-1074



BEFORE YOU DIG ANYWHERE IN PENNSYLVANIA: CALL 1-800-242-1776. NON-MEMBERS MUST BE CONTACTED DIRECTLY. PA LAW REQUIRES THREE WORKING DAYS NOTICE TO UTILITIES BEFORE YOU EXCAVATE, DRILL, BLAST OR DEMOLISH.

ONLY THOSE PLANS INCORPORATING THE RAISED PROFESSIONAL SEAL SHOULD BE CONSIDERED OFFICIAL AND RELIED UPON BY USER. THIS PLAN IS PREPARED SPECIFICALLY FOR THE CLIENT AND PROJECT DESIGNATED HEREON. MODIFICATION, REVISION, DUPLICATION OR USE WITHOUT THE CONSENT OF GILMORE & ASSOCIATES, INC. IS PROHIBITED. © COPYRIGHT 2006 GILMORE & ASSOCIATES, INC. ALL RIGHTS RESERVED.

**APPENDIX D**

OWNER: NORTHAMPTON TOWNSHIP 55 TOWNSHIP ROAD RICHBORO, PA 18954	REV. TAX MAP PARCEL NO.: -	DESCRIPTION -	DATE	BY
MUNICIPAL FILE NO.: -	TOTAL AREA: -	TOTAL LOTS: -	DATE: 9-10-07	SCALE: 1"=150'
		<b>HOLLAND STREET LIGHT IMPLEMENTATION PLAN</b> NORTHAMPTON TOWNSHIP, BUCKS COUNTY, PENNSYLVANIA		
		<b>GILMORE &amp; ASSOCIATES, INC.</b> <b>ENGINEERING &amp; CONSULTING SERVICES</b> <small>3915 LANTANA DRIVE, HAVERTOWN, PA 19342 • 610-261-5400 • WWW.GILMOREANDASSOCIATES.COM</small>		
150 0 150 300 SCALE IN FEET		JOB NO.: 2007-07071 SHEET NO.: 1 OF 1		
DESIGNED BY: MPR	DRAWN BY: MPR	CHECKED BY: CEG		